

KD6 MARINE DIESEL

TECHNICAL DATA

TYPE	HORIZONTAL, SINGLE CYLINDER, FOUR STROKE, WATER COOLED, INDIRECT INJECTION, WET CYLINDER LINER
BORE/STROKE	75/75 mm
DISPLACEMENT	330 cc
COMPRESSION RATIO	21:1
MAX OUTPUT	4.43 KW @ 2600 REV/MIN 6.00 HP @ 2600 REV/MIN
MAX TORQUE	16.9 N.m. @ 1800 REV/MIN 12.5 LBF.FT. @ 1800 REV/MIN
COOLING METHOD	RAW WATER JABSCO PUMP
STARTING METHOD	HAND CRANK & ELECTRIC START
SPECIFIC FUEL CONSUMPTION	220 gms/hp.hr Max
LUBRICATION	PUMP & SPLASH
GEARBOX	MANUAL 2:1 REDUCTION FNR LEVER OR REMOTE CONTROL
DIMENSIONS (LxWxH) mm	700 X 620 X 450
NETT WEIGHT WITH GEARBOX	128 KG.

**KD6 - 038 GEARBOX (DRY EXHAUST)**

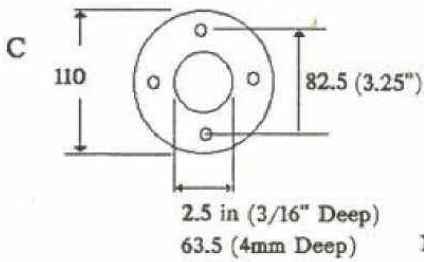
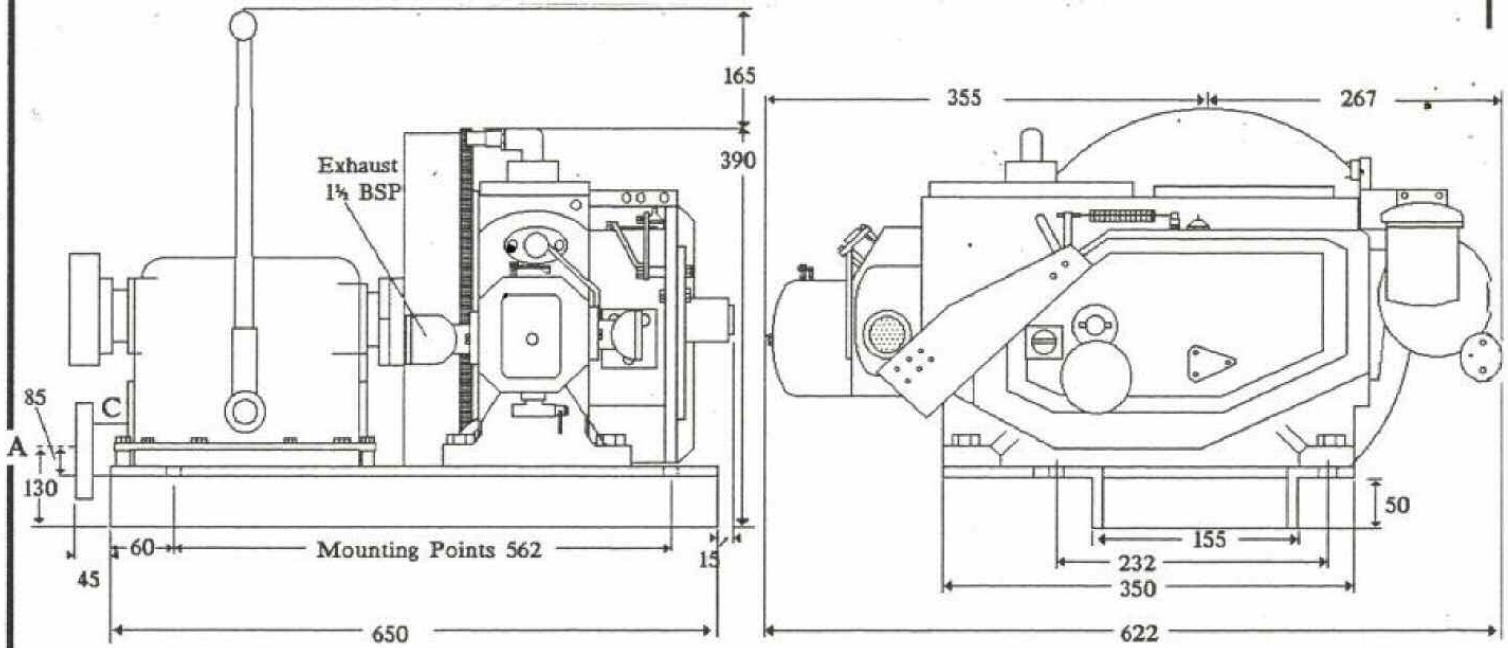

- A - Gearbox Output Centreline
- C - Gearbox Coupling
- \* - Engine Rubber Mounts See Drawing

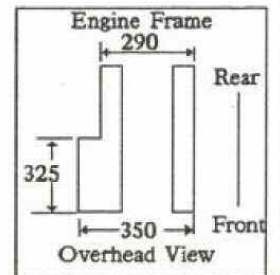

Note: If gearbox remote control fitted o/a height 390

Revisions

Kingfisher . . . . .

Engine Installation  
KD6 - 038 Gearbox

Starboard - Front View

Drawn  
EM

Traced

Checked  
*Shea*

Approved

Date  
0294

Drawing No: KD6 a